



**SantaLuzia<sup>®</sup>**  
**PRODUCT DATASHEET**

Address : 555 Heriberto Eftting  
Santa Luzia Braço do Norte / SC - Brazil  
Zip Code: 88750-000  
Contact: +55 (48) 3651-1363  
[Customersuport@santaluziamouldings.com](mailto:Customersuport@santaluziamouldings.com)

**INDEX:**

- 1. Product Raw Material ..... 3
- 2. Product Composition and Company Identification ..... 3
- 3. Product Features ..... 3
  - 3.1. Thermal Expansion ..... 3
  - 3.2. Water Absorption ..... 3
  - 3.3. Flamability ..... 3
  - 3.4. Exposure to Coastal Environments (indoors)..... 3
  - 3.5. Resistance to Cleaning Products ..... 3
  - 3.6. Pest Resistance ..... 4
  - 3.7. Application Environments ..... 4
  - 3.8. Electric Materials ..... 4
- 4. Finishing ..... 4
  - 4.1. Hot Stamping ..... 4
  - 4.2. Wrapping Film ..... 4
  - 4.3. Acrylic Ink ..... 4
- 5. Repainting Procedures ..... 5
  - 5.1. Acrylic Ink (Solvent & Water Based) ..... 5
  - 5.2. Polyurethane Ink ..... 5
- 6. Presentation, Packaging and Storage ..... 6
- 7. Technical Information Table ..... 6
  - 7.1 Explanatory Notes: ..... 7
- 8. Quantify of Bases Required ..... 7
- 9. Baseboard installation tips ..... 8
  - 9.1. In case of T-Brackets : ..... 8
- 10. How to Cut Santa Luzia’s Bases and Casings ..... 9
  - 10.1. How to Cut Santa Luzia’s Bases and Casings ..... 9
  - 10.2. 90° Angle Inner Corner Seamless Joints ..... 9
- 11. Finish ..... 9
  - 11.1. Top Door Corner 45° Angle Finish ..... 9
  - 11.2. Plinth Block and Rosettes Installation ..... 9
- 12. Wall paneling tips ..... 10
  - 12.1. 45° Union: ..... 11
  - 12.2. Ceiling application: ..... 11
- 13. Important Notice to the Consumer ..... 11



### 1. Product Raw Material

All profile lines (bases, casings, battens, wall panel and slat) are made with at least 96% of recycled polystyrene. This raw material comes from our own selective waste collection network. It's creates the opportunity to recycling this specified type of plastic knowed as styrofoam. Santa Luzia profile lines are 100% recyclable.

### 2. Product Compositon and Company Identification

<b>PRDUCT:</b>	<b>POLYSTYRENE PROFILES</b>
<b>COMPOSITION:</b>	96% Recycled Polystyrene and 4% Virgin Polystyrene
<b>FINISH:</b>	<ul style="list-style-type: none"> <li>• Hot Stamping Finish</li> <li>• Polypropylene Film Finish</li> <li>• Acrylic Paint</li> </ul>
<b>COMPANY:</b>	Industria e Comercio de Molduras Santa Luzia LTDA.
<b>ADDRESS:</b>	Heriberto Effting Street, 555 – Braço do Norte /SC – CEP 88750 000
<b>PHONE:</b>	+55 48 3651 1300
<b>EMAIL:</b>	customersupport@santaluziamouldings.com
<b>WEBSITE:</b>	www.industriasantaluzia.com.br/en

### 3. Product Features

#### 3.1. Thermal Expansion

Santa Luzia's polystyrene products have a characteristic thermal expansion of 0.15% for a temperature variation of 50 °C (122 °F).

#### 3.2. Water Absorption

The evaluation of the water absorption of Santa Luzia's products was made by changing the weight and dimensions of the product after immersion in water for 24 hours.

The variation in the weight of the products was 0.91% following the ASTM D 570 - 98. This variation does not change the characteristics of the product. Dimensional variation this did not occur due to water absorption.

#### 3.3. Flamability

The products have the characteristic of propagating flame.

#### 3.4. Exposure to Coastal Environments (indoors).

Santa Luzia's polystyrene products do not show any kind of alteration when exposed to coastal conditions. In other words, they are indicated for use in these places, as long as they are indoors.

#### 3.5. Resistance to Cleaning Products

The indicated cleaning product is neutral detergente diluted in water. The cleaning of the products must be done with the help of a soft cloth or sponge.

Note: The cleaning tests carried out for the preparation of this data sheet were carried out on factory finished products. If other types of paint are applied to the product post purchase, the new paint manufacturer's recommendations must be observed.



### 3.6. Pest Resistance

Pests such as termites, borers and other insects do not feed on this product.

### 3.7. Application Environments

The products are not indicated for external areas and in environments that have direct incidence of solar radiation, as it can cause changes on the product's finish.

This product can be used in humid environments, as it does not change when exposed to humidity, as shown in item 3.2.

The indicated application environments for these products is spaces with a temperature below 50°C (122°F), bearing in mind that any temperature variation will subject the products to thermal expansion as shown in item 3.1 of this document.

### 3.8. Electric Materials

Santa Luzia's products, which have the feature called "Wire Path", were developed to help pass specific wires/cables when necessary. It is suggested that only the following types of wires/cables be used, such as: internet cables, telephone cables, 12-volt power cables, tv antenna cables, among others.

Energized wires and cables with a voltage equal to or greater than 12 volts must not be used.

## 4. Finishing

### 4.1. Hot Stamping

The profiles are supplied with a Hot Stamping finish on a pigmented polyester tape.

**Painting is not recommended.**

### 4.2. Wrapping Film

Line profiles are supplied finished, coated with a Polypropylene film, with the following characteristics:

- |   |  |
|---|--|
| <ul style="list-style-type: none"> <li>• Scratch resistance;</li> <li>• Abrasion resistance;</li> <li>• Chemical resistance;</li> <li>• Waterproof;</li> <li>• Steam resistance;</li> <li>• Mildew resistance;</li> <li>• Light resistance;</li> <li>• Easy to clean;</li> <li>• Barrier against</li> </ul> | <ul style="list-style-type: none"> <li>formaldehyde;</li> <li>• Free of formaldehyde;</li> <li>• Free of halogen components;</li> <li>• Free of plasticizers;</li> <li>• Variety of designs;</li> <li>• Deep stamping;</li> <li>• Soft touch surface;</li> </ul> |
|---|--|

**Painting is not recommended.**

### 4.3. Acrylic Ink

Line profiles are supplied finished, painted with acrylic paint.

Hot Stamping, Veneer and Black Collection finishes are not recommended for re-painting. Only factory painted products are recommended for repainting when desired, and when doing so, follow the recommendations listed below.



## 5. Repainting Procedures

### 5.1. Acrylic Ink (Solvent & Water Based)

- a. It is recommended that the paint or enamel used, to repaint the products, be the same (type & brand) used in openings such as: doors, trim, windows, etc. In order to minimize possible shade variations.
- b. The use of coarse sandpaper or any other type of procedure that do not removes the original finish. Remaining the original finish is recomendend to repainting sucess. The use of fine sandpaper (900-1200) or steel sponge is recommended. Perform a light and homogeneous sanding on the entire profile, not removing the original finish.
- c. The product can be painted with acrylic, polyurethane and synthetic paint as well as enamels. We suggest that to customize them in white, use paint or water-based enamel. In cases of personalization with colors other than white, solvent-based paint or enamel is recommended.

### 5.2 Polyurethane Ink

To repaint Santa Luzia's products, except those from the Black Collection, Wrapping Film and those with Hot Stamping finish, we suggest the following steps:

- a. It is recommended that the paint or enamel used, to repaint the products, be the same (type & brand) used in openings such as: doors, trim, windows, etc. In order to minimize possible shade variations.
- b. The use of coarse sandpaper or any other type of procedure that do not removes the original finish. Remaining the original finish is recomendend to repainting sucess. The use of fine sandpaper (900-1200) or steel sponge is recommended. Perform a light and homogeneous sanding on the entire profile, not removing the original finish.
- c. Apply ONLY thin/light coats of PU primer, no more than two layers.
- d. Finally, after the primer base has cured, apply ONLY thin/light, one or two coats of PU Enamel finish.

Take caution, as the PU Enamel finish is applied together with a solvent Ex: Thinner. If the proportion is too high, exist the possibility of product "aggression" which results in the appearance of small bubbles on the product's finish.

A test is suggested beforehand to find the ideal proportion, since the proporcion of the PU Enamel finish varies from manufacturer to manufacturer.

A thin layer of paint is ALWAYS recommended at this stage.

The performance of the same paint can differ from manufacturer to manufacturer and each type of finishing paint has a specific performance. For more information, contact the manufacturer of the paint to be used. It is important to point out that the performance of the new finish will depend on the quality of the paint and the application. The manufacturer's specifications must be considered.

It is not recommended to paint mouldings that are painted other than white, or finished with Hot Stamping and lamination finish Polymeric from factory.



## 6. Presentation, Packaging and Storage

The products are presented in individual packages with shrink-wrapped plastic and cardboard boxes. Each package contains the product name and installation instructions. The disposal of packaging materials must be carried out in compliance with local regulations. The packaging material (shrink-wrapped plastic and cardboard boxes) are all recyclable.

Storage can be done both vertically and horizontally, as long as it does not cause the products to bend or suffer damage. Store under protective covering to prevent jobsite dirt.

Note: Profiles with special lengths can be made according to the Sales Policy, and the type of packaging can also be negotiated on a case-by-case basis.

Note: The tests carried out for the preparation of the technical sheet were carried out on profiles with line finishes. If other types of paint are applied, the manufacturer's recommendations must be observed as showed above.

## 7. Technical Information Table

Technical Attributes	Test Method	Results
<b>Water Absorbtion (24h Imersion)</b>	ASTM D 570-98 <sup>I.</sup>	0,91 %
<b>Thermal Expansion (<math>\Delta T= 50\text{ }^{\circ}\text{C}</math> (122 °F))</b>	ASTM E 831-14 <sup>II.</sup>	0.15%
<b>Optical Smoke Density</b>	ASTM E662 <sup>III.</sup>	503,1
<b>IZOD Impact Resistance</b>	ASTM D 256-10 <sup>IV.</sup>	6,55 J/m
<b>Flexural Strength</b>	ASTM D 790-10 <sup>V.</sup>	10 MPa
<b>VI. Proposition 65 California – USA<sup>VI</sup></b>	OEHHA	Approved
<b>VII. Volatile Organic Compounds (96h)<sup>VII.</sup></b>	CDPH/EHLB/Standard Method V1.1 (Sect. 01350)	≤ 0,5
	Office	Approved
	Classroom	Approved
<b>Density</b>	Santa Luzia Internal Procedure	31,2 (lb/ft <sup>3</sup> ) 500 (kg/m <sup>3</sup> )
<b>Product Width/ Height</b>	-	1-13/16" (3 cm) to 9-13/16" (25 cm)
<b>Product Length</b>	-	8 ft (2.44 m)
<b>Product Thickness</b>	-	5/16" (8 mm) to 5/8" (16 mm)
<b>Maximum stacking</b>	-	12 Boxes



**7.1 Explanatory Notes:**

I.	ASTM D 570-98	This test method covers the determination of the relative rate of absorption of water by plastics when immersed.
II.	ASTM E 831-14	This test method determines the technical coefficient of linear thermal expansion of solid materials using thermomechanical analysis techniques.
III.	ASTM E662	This fire-test-response standard covers determination of the specific optical density of smoke generated by solid materials.
IV.	ASTM D 256-10	The test method describes impact testing according to the Izod method for determination of the pendulum impact resistance of plastics.
V.	ASTM D 790-10	This test method determine the flexural (bending) properties of reinforced and unreinforced plastics, high-modulus composites, and electrical insulation materials.
VI.	Propositon 65 California	Prop 65 prohibits anyone in the course of doing business in California or selling a product to a consumer in California to knowingly and intentionally expose any individual to a chemical, even in very minimal amounts, that the California OEHHA has added to the list, without giving a warning.
VII.	Volatile Organic Compounds	Volatile organic compounds (VOCs) are carbon containing chemicals that vaporize and can enter the body through normal breathing.

**8. Quantify of Bases Required**

PS (Polystyrene) – 7' 10-1/2" ( 2,40m ) Bases

Make sure that the quantity of bases to be used has been calculated based on the perimeter of the installation area. To ensure that the quantity is sufficient, add 10% to the measured amount to account for cuts or possible losses.

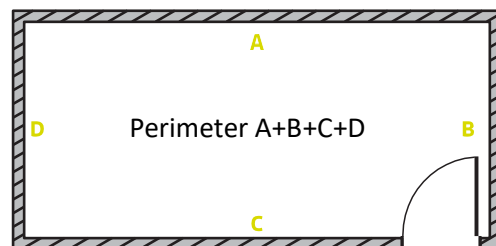

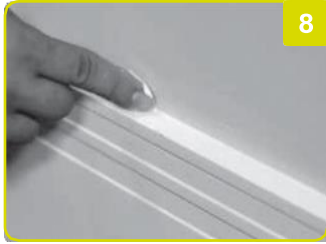
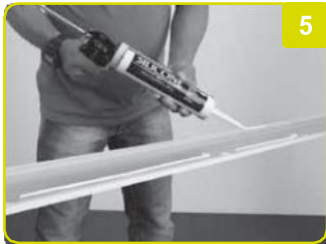
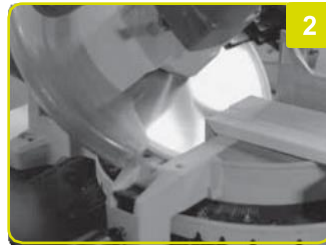
**9. Baseboard installation tips**

**1.** Prepare the surface where the product will be installed. It is very important that the surfaces are dry, free of dust, fungus, putty, plaster and elevations. A coat of paint is recommended on the wall where the product will be installed.

**2.** Cut the profile at 45° (by adjusting the mitre saw bevel), as shown in image 2.

**3.** Clean the back of the profile.

**4.** Apply 1-9/16" (4 cm) pieces of Double Sided Tape on the backside of the product, with a maximum spacing of 15-3/4" (40 cm) between the tapes

NOTE: For installations on masonry, it is recommended to use either Heavy Duty Adhesive

**5.** Apply sinuous and continuous lines of Heavy Duty Adhesive or glue according to the size of your profile:

1-3/16" (3cm) to 1-15/16" (5cm) - 1 line

2-3/4" (7cm) to 5-7/8" (15cm) - 2 lines

7-7/8" (20cm) to 9-13/16" (25cm) - 3 lines

**6.** Now place the bar in the installation position and press it against the wall. For a more efficient result, press tight using your hand or gently hit with a rubber mallet for 30 seconds.

**7.** To minimize possible cracks on the joints, it is recommended to use instant super glue where the products will join.

**8.** After installing all the bars, apply Caulk or Sealant to the holes and joints. If necessary, also apply to the walls to eliminate possible imperfections in the masonry. Use a damp cloth to remove excess product.

**9.1. In case of T-Brackets :**

**A.** Cut a 3-15/16" (10 cm) piece of the product to serve as a template. On the back of the bar, in the existing slot to fit the T-Brackets, drill a hole.

Make sure the floor is level, place the template where the bar will be applied and mark the wall every 15-3/4" (40 cm) with a pencil, through the hole in the template

**B.** Drill the wall on the previous markings and insert a T-Brackets with a hammer. Next, apply the 1/2 inch brad nail in the T-Brackets. Do not use screws.

**C** and **D.** Apply two parallel lines of Glue or Heavy Duty Adhesive on the backside of the bar. For bar over 5-7/8" (15cm) in width/height, apply at least 3 lines of Heavy Duty Adhesive. Then, place the bar where it will be applied and with your hands, make sure it connects to the T-Brackets you previously applied on the wall. Wipe off excess Glue or Heavy Duty Adhesive from the profile after installation.

For more information about this or other installation methods, contact us: C.S. +55 48 3651 1358 or by mail [Customersupport@santaluziamouldings.com](mailto:Customersupport@santaluziamouldings.com)





**10. How to Cut Santa Luzia's Bases and Casings**

**1**

**2**

**3**

**4**
**10.1. How to Cut Santa Luzia's Bases and Casings**

**1.** When installing Santa Luzia's bases and casings on a long wall, you can join several bars together. To do this, cut the ends of the bars at a 45° angle (by adjusting the bevel), using an electric mitre saw with a 96 teeth blade and 12 inch diameter.

**2.** Join the bars so that one cut completely covers the other.

**10.2. 90° Angle Inner Corner Seamless Joints**

**3.** Cut the bars that will be used in the inner corner with a miter saw at a 45° angle (frontside of the baseboard facing up and adjusting the bevel).

**4.** One of the bars must be cut upside down (still with the frontside of the moulding facing up) to fit with the other. After making the cuts, place one bar in contact with the other in the corner to make sure they fit perfectly, then, glue them.

**11. Finish**

**1**

**2**

**3**

**4**

**1.** Before making any cuts, leave the ends of the bases and casings at a 90° angle.

Make a cut at a 45° angle with the base in a horizontal position.

**NOTE:** The cut must be the same as the product's thickness

**2.** Keep the small piece you achieved after previously cutting, which should have one side cut at 45° and the other at 90°. It is the piece that will allow you to make the baseboard end. Turn the around and cut the other side of the base, also at a 45° angle, always with the frontside piece facing upwards.

**3 and 4.** Join the two parts cut at an angle with instant super glue.

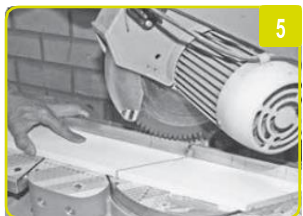
**11.1. Top Door Corner 45° Angle Finish**

**5**

**6**

**5.** Make straight cuts with the miter saw, at a 45° angle (adjusting the mitre), with the cases flat (horizontal position).

**6.** Join the cases so that the corners fit perfectly.

**11.2. Plinth Block and Rosettes Installation**

**7.** Apply a generous layer of Heavy Duty Adhesive.

Place the piece firmly against the wall and align it with the floor. Press it firmly against the wall for perfect adhesion.

**8.** For a better finish at the joints and between the wall and the pieces, follow the "Final Finishes with Caulk or Sealant" steps after application, as described in this manual.

**7**

**8**

**12. Wall paneling tips**

- a. Apply pieces of Double Sided Tape between 1' to 2' inch long, spaced no more than 15' inches apart. Start applying the Double Sided Tape at the ends of the bar and one more at each end. See Figure 01. Apply two strands of Heavy Duty Adhesive, continuous along the length of the bar following its guides on the back of the bar, see illustration figure 03.

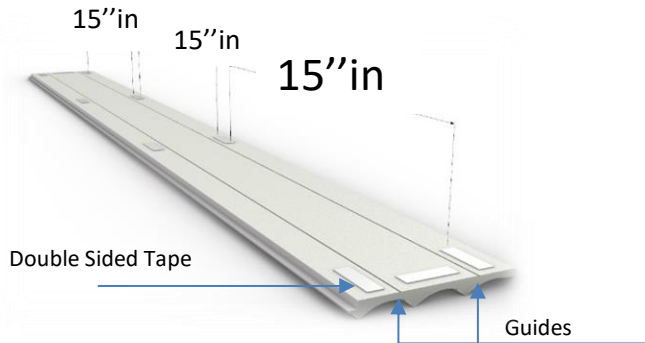
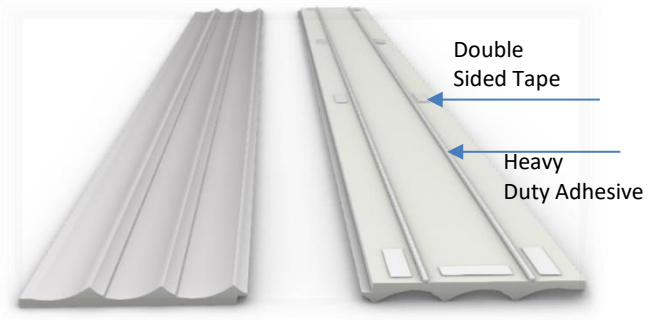
*figure 01*

*figure 02*
*Figure 03*

- b. Now place the bar in the installation position, fitting one into the other, and press it against the wall, see illustration figure 04. For a more efficient result, press for 30 seconds
- c. It is also possible for the bar to be pinned or screwed to the sides of the bar, in order to guarantee a more efficient fixing. The pin or screw must be applied at the ends where it will be overlapped by the following bars, thus finishing the perforated area.

*figure 04*

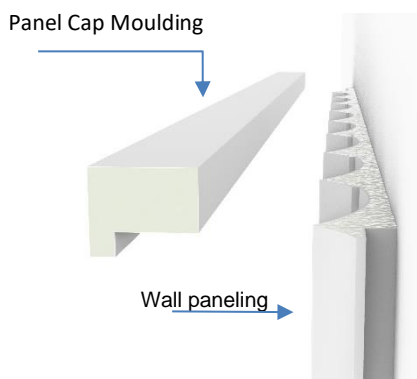
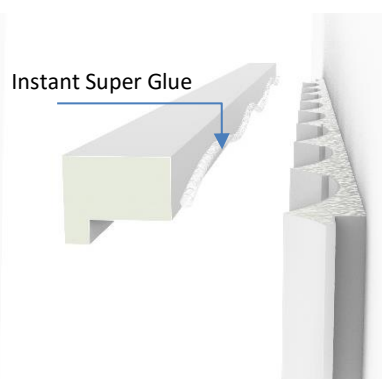
- d. If top or side finishing is required, use the Panel Cap Moulding.
- e. Apply a continuous strands of Instant Super Glue to the area of the bar that will be in contact with the wall, see illustration Figure 05 and 06 below. Now place the bar in the desired installation position and press it against the surface. For a more efficient result, hold for about 30 seconds.

*figure 05*

*figure 06*

**12.1. 45° Union:**

For sites with a height of more than 9' 2-1/4" ft , for example, which will require a butt joint between the bars. Avoid the straight cut, and use the 45° cut to reduce the appearance of the joint between the bars. When making the 45° cut, make it in the opposite direction to the observer. This will reduce the perception of a joint between the bars.

**12.2. Ceiling application:**

Use mechanical fasteners, such as a pin/screw, in addition to double-sided Tape and Heavy Duty Adhesive, see the wall application method mentioned above.

For more information about this or other installation methods, contact us: C.S. +55 48 3651 1358 or by mail [Customersupport@santaluziamouldings.com](mailto:Customersupport@santaluziamouldings.com)

**13. Important Notice to the Consumer**

**INSTALLED PRODUCT IS CONSIDERED ACCEPTED PRODUCT!**

Santa Luzia company is not responsible for the installation of the product.

Santa Luzia company reserves the right to make updates and/or changes to this document without prior notice.

To guarantee the quality of Santa Luzia products, it is important to follow the recommendations made in the manuals, which can be found on the product packaging and on our website ([www.industriasantaluzia.com.br/en/documents](http://www.industriasantaluzia.com.br/en/documents)).

Santa Luzia company does not have contracted, accredited or authorized installers in any way. Therefore, it is not responsible for providing installation services, which are the exclusive responsibility of the hired professionals.

For this reason, Santa Luzia does not authorize the use of its image, name or any form of use of its intangible property, in any way, to offer services by independent installers.

Any questions please contact us by email ([customersupport@santaluziamouldings.com](mailto:customersupport@santaluziamouldings.com) ).

